



- TASTE THE DIFFERENCE -

MODEL CS600

Our high volume, single-flavor, countertop soft ice cream machine, it's easy to operate and simple to clean. The CS600 is ideal for ice cream kiosks, busy restaurants and for high quality milkshake production.

The Electro Freeze Advantage

- **The Finest Frozen Product** consistently the best frozen product available. Smooth, creamy and profitable.
- **Self Closing Handle** makes this machine ideal for self-service buffet restaurants.
- **Patented Beater** gently blends reducing agitation and maintaining product quality and consistency.
- **Electronic Consistency Control** designed to dispense the finest frozen product available.
- **Air Filter** washable filter keeps the condenser clean.
- **Manufactured using the Latest Technology** designed to be easy to operate, with a long working life.
- **Experience Tells** Electro Freeze has been manufacturing soft ice cream machines in the U.S.A. since 1929.
- **All New Electro Freeze Machines** are supplied in the U.K. with a **Three Year Parts & Labour Warranty**.
- **Floor Standing Model Available (CS600/F)**

Optional

- **Top Air Discharge Chute** diverts the air flow up and reduces the space required by the unit.

HIGH CAPACITY GRAVITY SOFT ICE CREAM MACHINE

Compact Series



Floor Standing CS600/F

electrofreeze.com

FOR MORE INFORMATION CONTACT

(023) 8062 9520 • info@electrofreeze.co.uk

CS600 Soft Serve Freezer

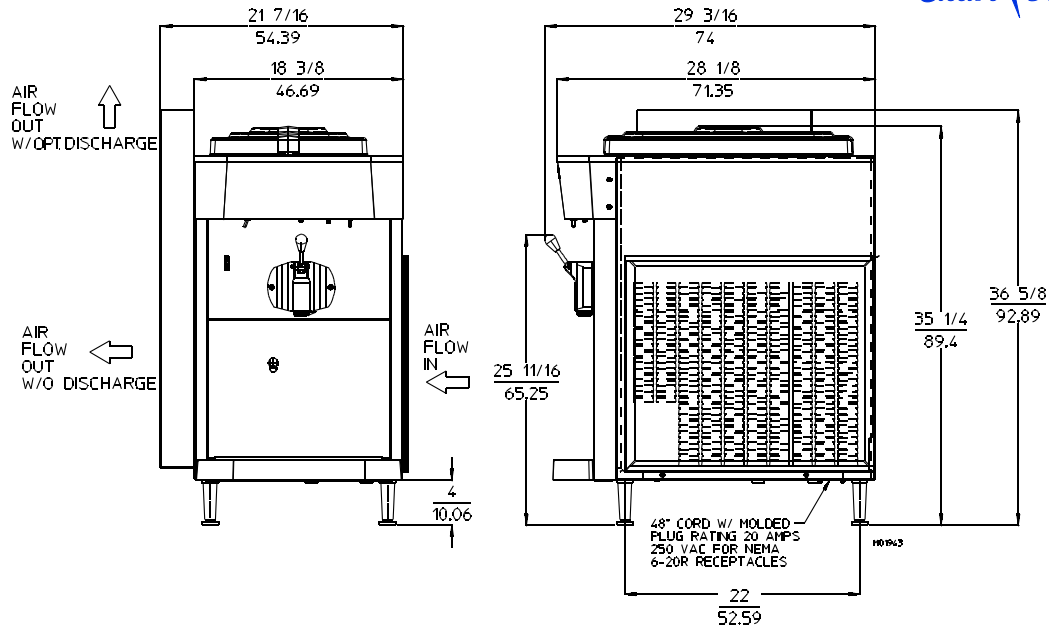

MODEL CS600 SPECIFICATIONS

Due to continual product improvements all specifications are subject to change without notice.

Weights	kgs.
Net	134
Crated	177
cu.m.	
Volume	1.2
Dimensions*	cm.
Width	47
Depth	71
Height	90
* without optional air deflector	
Electrical	Supply Required
1 Phase 220-240/50/1	20 Amp
<i>Check nameplate for exact electrical data.</i>	

Warranty

All new Electro Freeze Soft Ice Cream Machines are supplied in the U.K. with a Three Year Parts & Labour Warranty.

Electrical

A dedicated electrical connection is required. See electrical chart for the proper requirement.

Beater Motor

One, 1.5 hp.

Refrigeration Systems

One, 9,500 Btuh. R404a.
Btuh may vary depending on compressor used.

Air and Water Cooled

7.5cm air space required on sides and behind rear panel for proper air circulation

Mix Hopper Capacity: 18.8 litres

Freezing Cylinder Capacity: 3.5 Litres

Electro Freeze Sales (UK)

Citygrove Trading Estate, Woodside Road
Eastleigh, Hampshire, SO50 4ET (U.K.)
Phone (023) 8062 9520 International +44 23 8062 9520
Email: info@electrofreeze.co.uk
www.electrofreeze.co.uk

